

Project Portfolio

Huzaiifa H. Khan

www.huzaiifahkhan.com

e. huzhkhan@gmail.com

m. 519-588-6057

Autonomous EV Charging for Robo-Taxis

- **Watch Demo:** <https://youtu.be/w0QKPwgt9hM>
- An autonomous charging solution was designed and prototyped as a practical concept for the emerging robo-taxi industry
- An open source robot (AR3) was modified with a custom end-effector and perception system to locate and plug into a representative vehicle charge port using an object detection algorithm
- The charge port connector are modeled after the Chevy Bolt and EVgo DC Fast Charger, respectively
- Awarded \$4000 in project funding through:
 - General Motors Innovation Seed Fund
 - University of Waterloo Engineer of the Future Fund
 - ASME Northern Alberta Design Challenge Award
 - Classmates' Choice Award (Best-in-Class)

Home Position



Charging Position



Prototype CAD Model

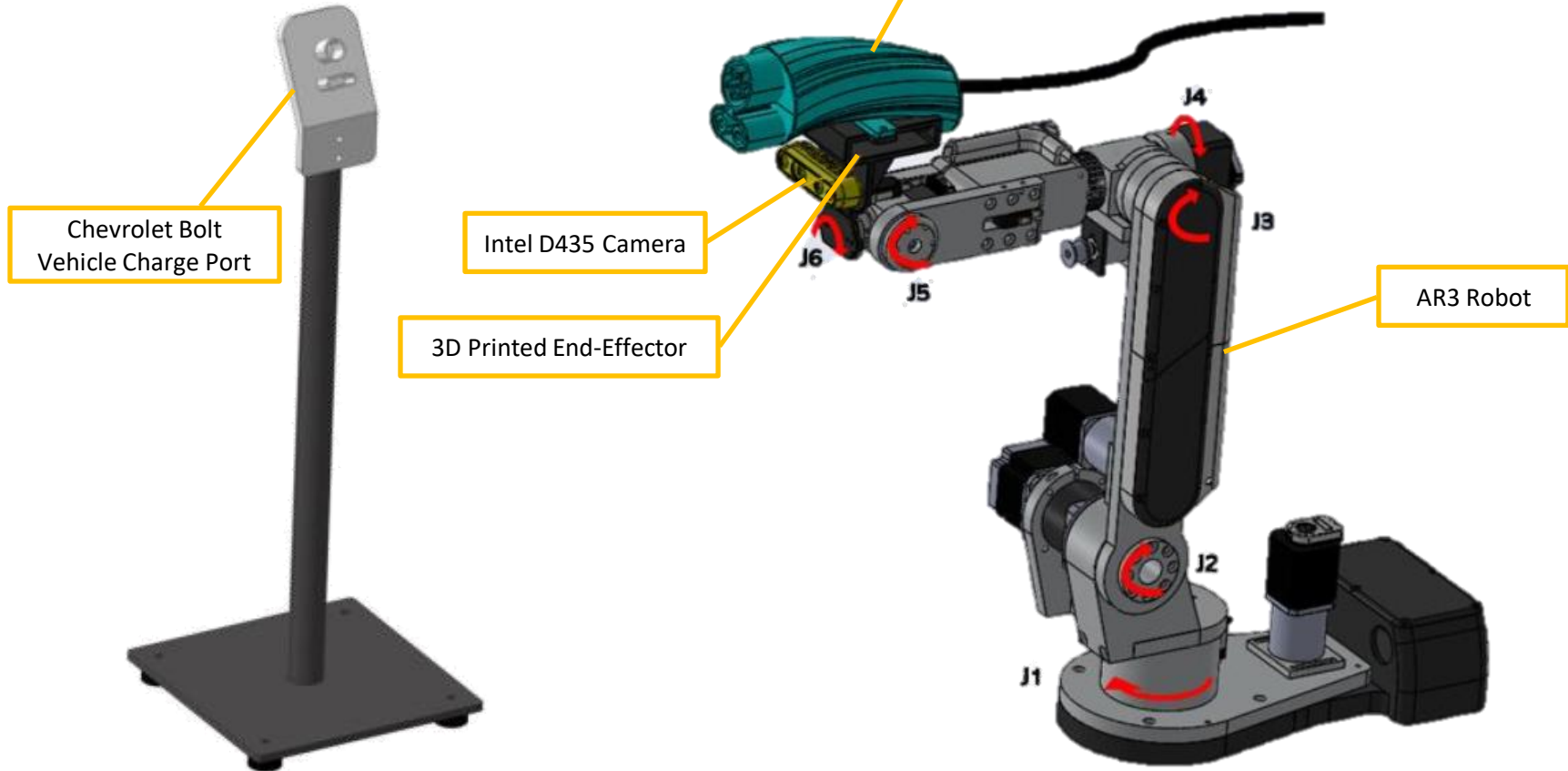

THC Wafer Card Test Fixture

- A custom 3D printed fixture was designed to assist with automated wafer card testing process
- Fixture possesses locating and alignment features for both the wafer card and custom designed PCBA
- +/- 5 degrees of adjustment is allowed in yaw to help align PCBA/wafer card interfacing pins
- Two clamps secure the assembly in position
- FEA simulation was performed to ensure the PCB does not experience severe bending when assembly is clamped
- CAD model designed in SolidWorks
- Electrical layout for PCB designed in KiCAD

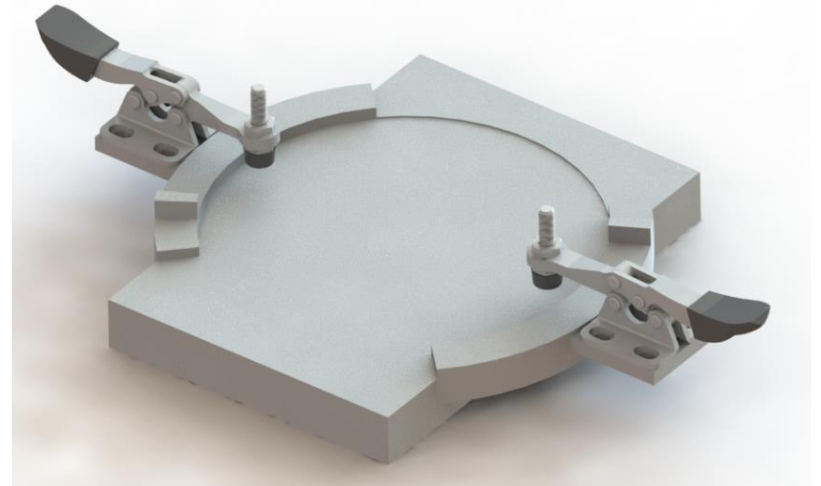
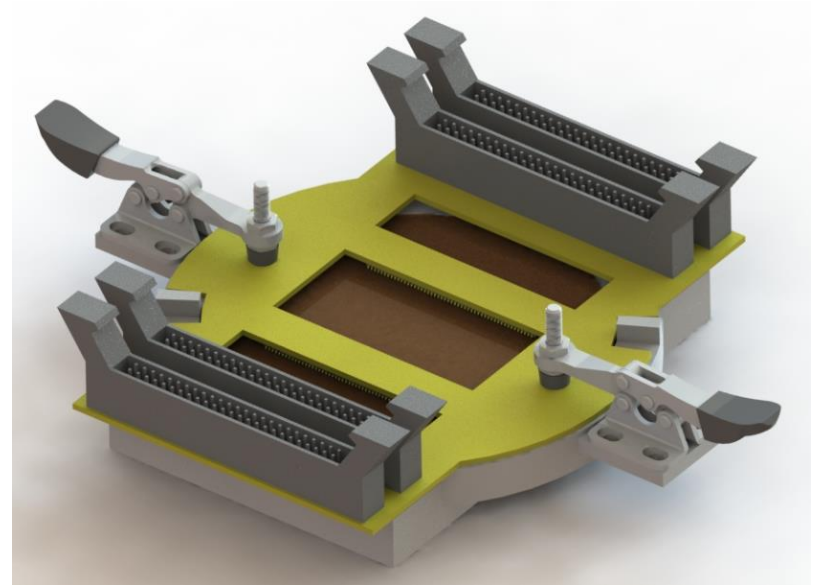

4-Layered PCB for Wafer Card Testing

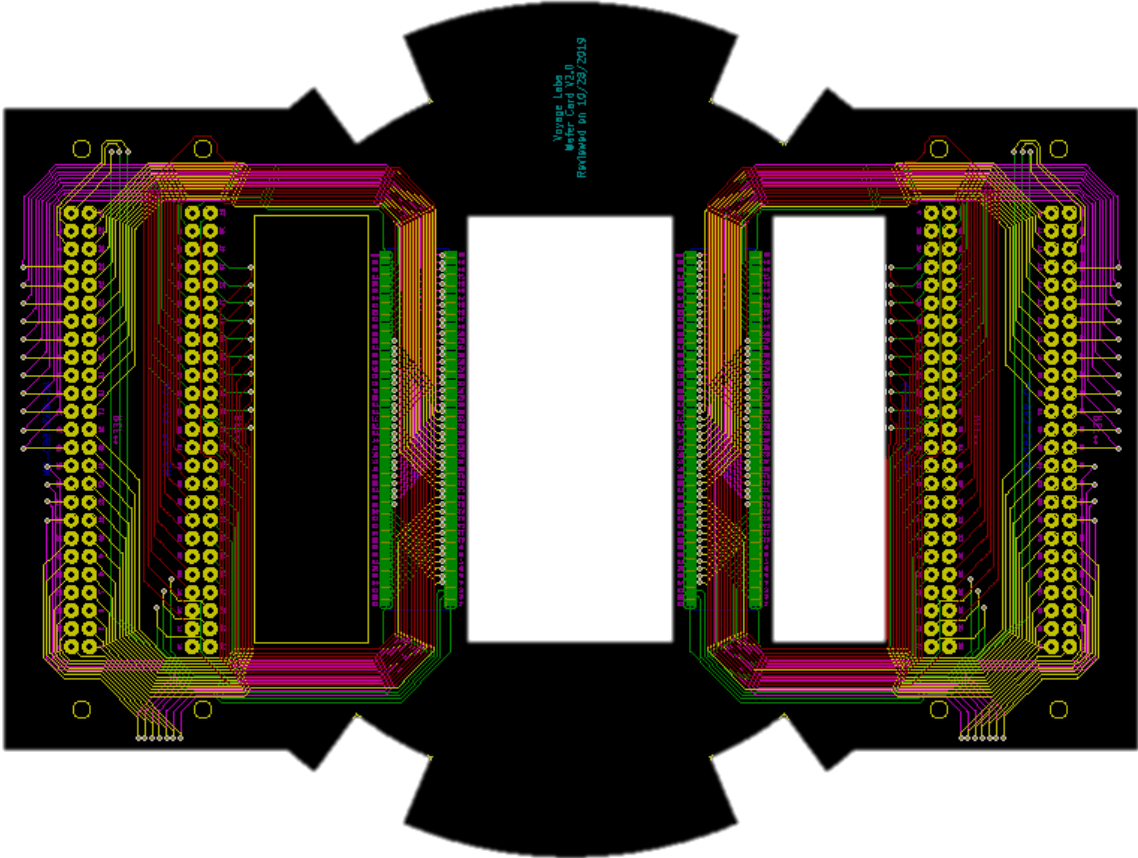

Underwater ROV

- Existing design of ROV was optimized to improve its maneuverability by 44% and speed by 50%
- Lift motor (bottom) repositioned to align with ROV's CoM in order to increase stability
- Motors are actuated using an Arduino and a PS2 controller
- CAD model designed in SolidWorks

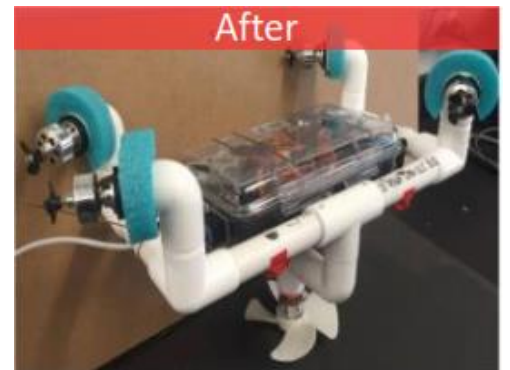
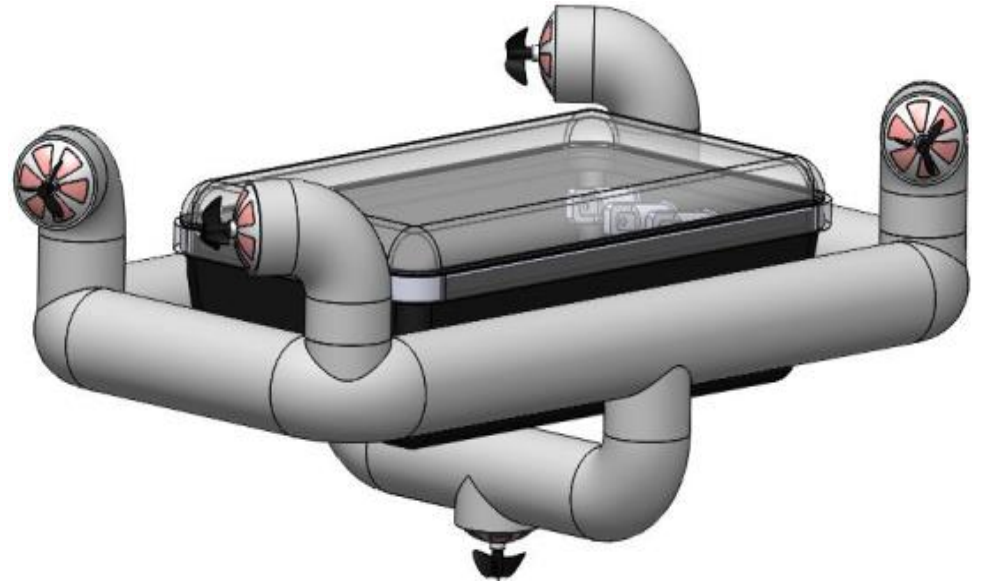

Underwater ROV Exploded View

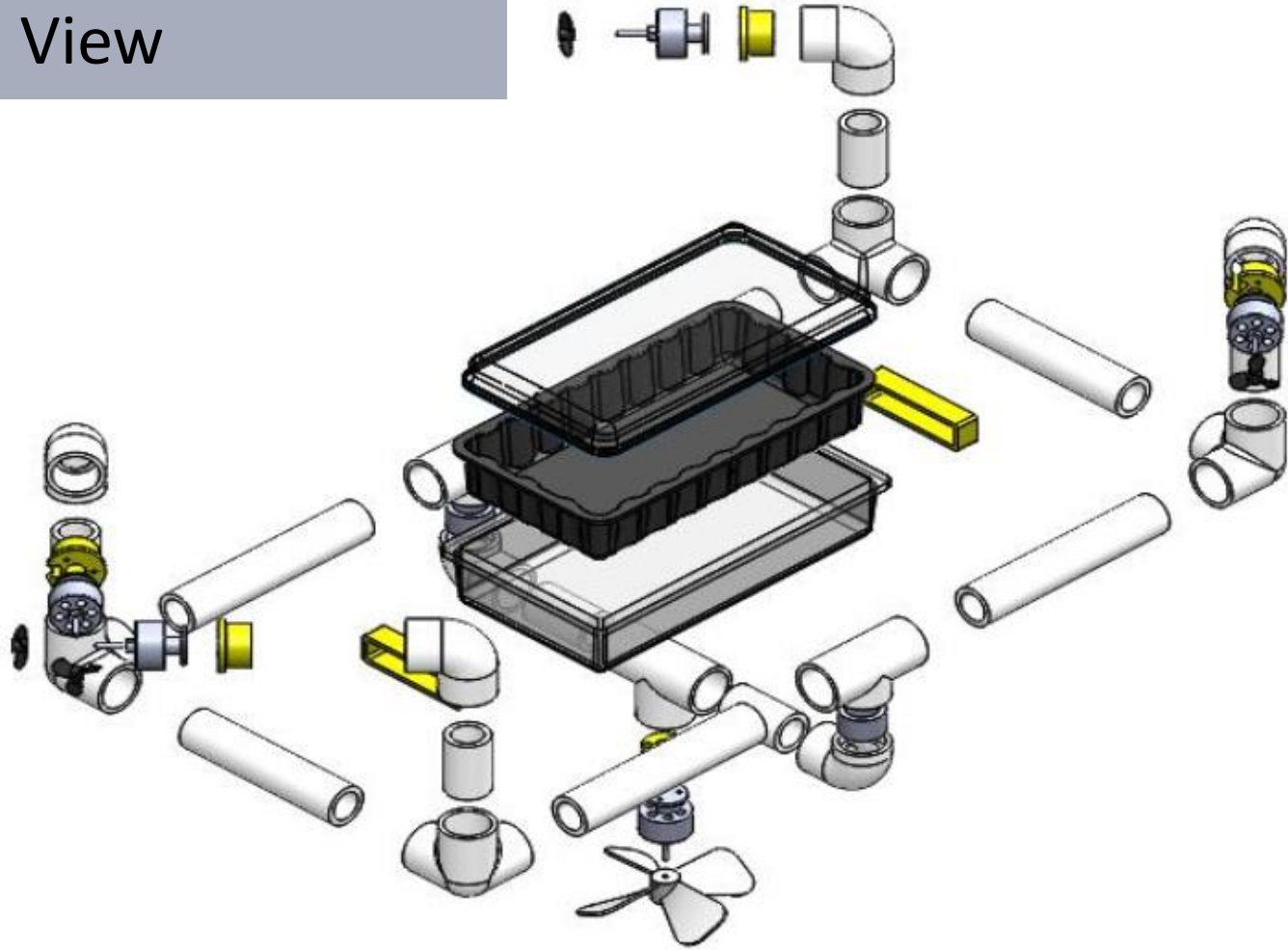

Mechanical Press for Blanking DP980 Steels

- Designed to deliver 184 kN punch force for blanking 3.2 mm thick sheet metal
- Punch operates at 20 SPM with an 88:1 gear reduction in gear train
- Design optimized for minimal footprint
- Preliminary design of drive shaft, intermediate shaft and crankshaft was conducted using Shigley's Mechanical Design Handbook
- CAD model designed in SolidWorks

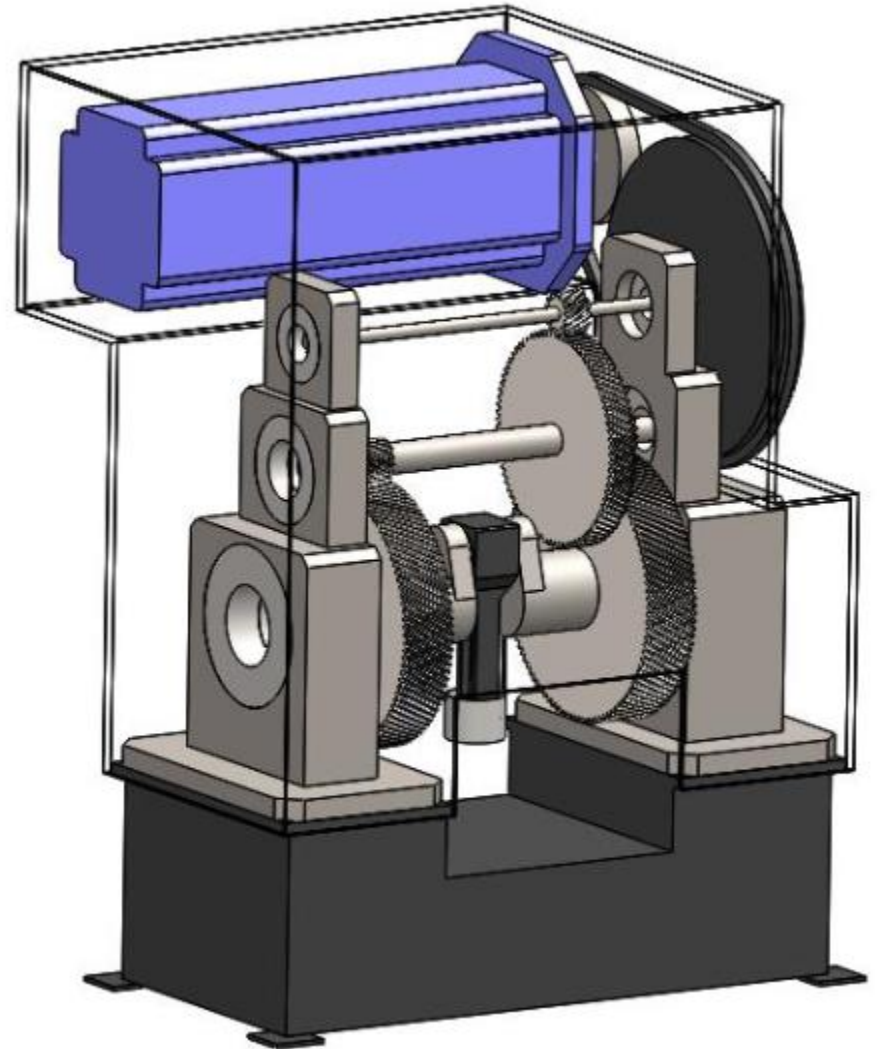

Mechanical Press Labeled Gear Train

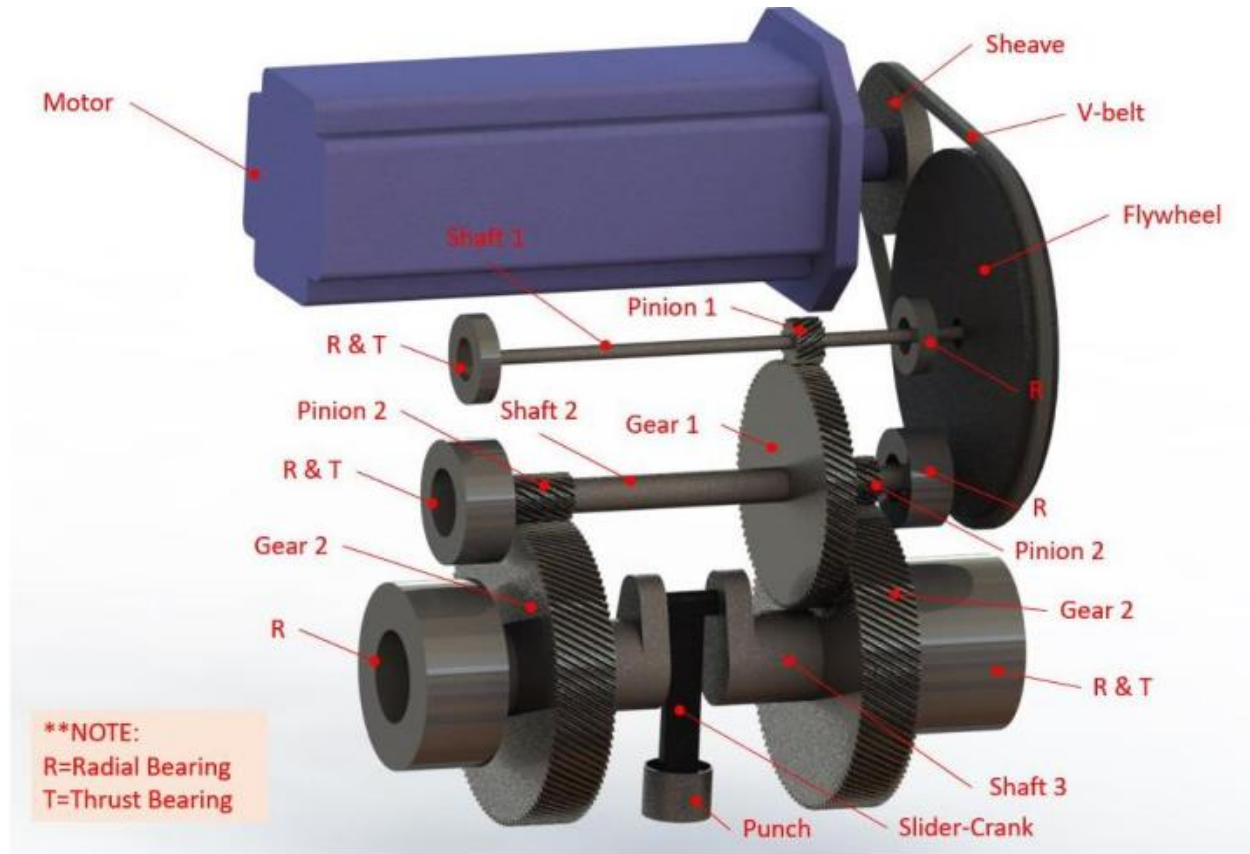

Temperature Data Logger (UW Formula Hybrid SAE)

- Data logger was used to monitor ATF temperature during Wet Rotor Cycle Testing for UWFH SAE
- Temperature data was used to determine the volume of ATF required to maintain critical stator temperature
- Setup includes Arduino, thermocouples and amplifiers
- MATLAB script was written to graph temperature profile along stator geometry

